

TECHNICAL REPORT

Electrical steel – Reverse bend test method for electrical steel strip and sheet





THIS PUBLICATION IS COPYRIGHT PROTECTED
Copyright © 2018 IEC, Geneva, Switzerland

All rights reserved. Unless otherwise specified, no part of this publication may be reproduced or utilized in any form or by any means, electronic or mechanical, including photocopying and microfilm, without permission in writing from either IEC or IEC's member National Committee in the country of the requester. If you have any questions about IEC copyright or have an enquiry about obtaining additional rights to this publication, please contact the address below or your local IEC member National Committee for further information.

IEC Central Office
3, rue de Varembe
CH-1211 Geneva 20
Switzerland

Tel.: +41 22 919 02 11
info@iec.ch
www.iec.ch

About the IEC

The International Electrotechnical Commission (IEC) is the leading global organization that prepares and publishes International Standards for all electrical, electronic and related technologies.

About IEC publications

The technical content of IEC publications is kept under constant review by the IEC. Please make sure that you have the latest edition, a corrigenda or an amendment might have been published.

IEC Catalogue - webstore.iec.ch/catalogue

The stand-alone application for consulting the entire bibliographical information on IEC International Standards, Technical Specifications, Technical Reports and other documents. Available for PC, Mac OS, Android Tablets and iPad.

IEC publications search - webstore.iec.ch/advsearchform

The advanced search enables to find IEC publications by a variety of criteria (reference number, text, technical committee,...). It also gives information on projects, replaced and withdrawn publications.

IEC Just Published - webstore.iec.ch/justpublished

Stay up to date on all new IEC publications. Just Published details all new publications released. Available online and also once a month by email.

Electropedia - www.electropedia.org

The world's leading online dictionary of electronic and electrical terms containing 21 000 terms and definitions in English and French, with equivalent terms in 16 additional languages. Also known as the International Electrotechnical Vocabulary (IEV) online.

IEC Glossary - std.iec.ch/glossary

67 000 electrotechnical terminology entries in English and French extracted from the Terms and Definitions clause of IEC publications issued since 2002. Some entries have been collected from earlier publications of IEC TC 37, 77, 86 and CISPR.

IEC Customer Service Centre - webstore.iec.ch/csc

If you wish to give us your feedback on this publication or need further assistance, please contact the Customer Service Centre: sales@iec.ch.



TECHNICAL REPORT

Electrical steel – Reverse bend test method for electrical steel strip and sheet

INTERNATIONAL
ELECTROTECHNICAL
COMMISSION

ICS 29.030

ISBN 978-2-8322-5616-9

Warning! Make sure that you obtained this publication from an authorized distributor.

CONTENTS

FOREWORD.....	3
INTRODUCTION.....	5
1 Scope.....	6
2 Normative references	6
3 Terms and definitions	6
4 Symbols and designations	7
5 Principles	7
6 Apparatus.....	7
7 Test specimen	8
8 Procedure.....	8
9 Expression of results	10
Annex A (informative) An example of the apparatus used for the reverse bend test	11
Annex B (informative) Dependence of the number of bends on tensile force applied to the test specimen.....	13
B.1 General.....	13
B.2 Test results.....	13
B.3 Deformation situation of the specimen after failure.....	14
B.4 Conclusions	15
Bibliography.....	16
Figure 1 – Apparatus for the reverse bend test of Mode A and Mode B	7
Figure 2 – Schematic view of the mandrels for Mode A and Mode B	8
Figure 3 – Method of counting reverse bends.....	9
Figure A.1 – Schematic view of a specially designed apparatus for the reverse bend test.....	11
Figure B.1 – Number of bends for different tensile forces with Mode A.....	13
Figure B.2 – Number of bends for different tensile forces with Mode B.....	14
Figure B.3 – Side views of the specimens after failure with Mode A and Mode B for different tensile forces	14

INTERNATIONAL ELECTROTECHNICAL COMMISSION

**ELECTRICAL STEEL –
REVERSE BEND TEST METHOD FOR
ELECTRICAL STEEL STRIP AND SHEET**

FOREWORD

- 1) The International Electrotechnical Commission (IEC) is a worldwide organization for standardization comprising all national electrotechnical committees (IEC National Committees). The object of IEC is to promote international co-operation on all questions concerning standardization in the electrical and electronic fields. To this end and in addition to other activities, IEC publishes International Standards, Technical Specifications, Technical Reports, Publicly Available Specifications (PAS) and Guides (hereafter referred to as "IEC Publication(s)"). Their preparation is entrusted to technical committees; any IEC National Committee interested in the subject dealt with may participate in this preparatory work. International, governmental and non-governmental organizations liaising with the IEC also participate in this preparation. IEC collaborates closely with the International Organization for Standardization (ISO) in accordance with conditions determined by agreement between the two organizations.
- 2) The formal decisions or agreements of IEC on technical matters express, as nearly as possible, an international consensus of opinion on the relevant subjects since each technical committee has representation from all interested IEC National Committees.
- 3) IEC Publications have the form of recommendations for international use and are accepted by IEC National Committees in that sense. While all reasonable efforts are made to ensure that the technical content of IEC Publications is accurate, IEC cannot be held responsible for the way in which they are used or for any misinterpretation by any end user.
- 4) In order to promote international uniformity, IEC National Committees undertake to apply IEC Publications transparently to the maximum extent possible in their national and regional publications. Any divergence between any IEC Publication and the corresponding national or regional publication shall be clearly indicated in the latter.
- 5) IEC itself does not provide any attestation of conformity. Independent certification bodies provide conformity assessment services and, in some areas, access to IEC marks of conformity. IEC is not responsible for any services carried out by independent certification bodies.
- 6) All users should ensure that they have the latest edition of this publication.
- 7) No liability shall attach to IEC or its directors, employees, servants or agents including individual experts and members of its technical committees and IEC National Committees for any personal injury, property damage or other damage of any nature whatsoever, whether direct or indirect, or for costs (including legal fees) and expenses arising out of the publication, use of, or reliance upon, this IEC Publication or any other IEC Publications.
- 8) Attention is drawn to the Normative references cited in this publication. Use of the referenced publications is indispensable for the correct application of this publication.
- 9) Attention is drawn to the possibility that some of the elements of this IEC Publication may be the subject of patent rights. IEC shall not be held responsible for identifying any or all such patent rights.

The main task of IEC technical committees is to prepare International Standards. However, a technical committee may propose the publication of a technical report when it has collected data of a different kind from that which is normally published as an International Standard, for example "state of the art".

IEC TR 63114, which is a technical report, has been prepared by IEC Technical Committee 68: Magnetic alloys and steels.

The text of this technical report is based on the following documents:

Enquiry draft	Report on voting
68/565/DTR	68/579A/RVDTR

Full information on the voting for the approval of this technical report can be found in the report on voting indicated in the above table.

This document has been drafted in accordance with the ISO/IEC Directives, Part 2.

The committee has decided that the contents of this document will remain unchanged until the stability date indicated on the IEC website under "<http://webstore.iec.ch>" in the data related to the specific document. At this date, the document will be

- reconfirmed,
- withdrawn,
- replaced by a revised edition, or
- amended.

A bilingual version of this publication may be issued at a later date.

INTRODUCTION

Before the preparation of this document, the working group discussed the actual situation of industry concerning the application of reverse bend tests for the evaluation of the ductility of electrical steel strip and sheet, including non-oriented and grain-oriented materials. The following points were noted:

- The reverse bend test is widely used in industry for the evaluation of ductility of electrical steel, and is referenced by the products standards;
- In actual industry practice, the reverse bend test mainly uses as test specimens Epstein strips of 30 mm in width;
- The product standards of IEC 60404-8-4 [1]¹, IEC 60404-8-7 [2] and IEC 60404-8-8 [3] refer to ISO 7799 for the reverse bend test. However, ISO 7799 specified the width of test specimen to be less than the width of the Epstein strip (30 mm). Therefore, the Epstein strip does not meet with the requirement of ISO 7799;
- There are two modes for the reverse bend test, Europe generally adopts the method of reverse bend test according to ISO 7799 (defined as Mode A), alternatively America and Asia generally adopt that according to ASTM A720 [4] (for non-oriented materials) and JIS C2550 [5] (defined as Mode B), see also the references [6-7];

NOTE ASTM A721 [8] defined a bend method, which is different from the reverse bend test, to determine the ductility of grain-oriented materials.

- The apparatus and the requirements for the reverse bend test are slightly different between Mode A and Mode B, especially on the gap between the specimen and the round edges of the clamp and the requirement that a tensile force is applied to the test specimen; This may cause different deformation mechanisms during bending;
- A comparison test between the two modes has been carried out. It was revealed that number of bends obtained with Mode A and Mode B are different.

The above points indicate the need for a standardization of the reverse bend test method particular to electrical steel to explain how to use the two modes in industry.

This document describes the general principle and technical details of the reverse bend test especially for the evaluation of the ductility of electrical steel with respect to the two modes, Mode A according to ISO 7799 and Mode B according to ASTM A720 and JIS C2550.

Annex A provides information on a specially designed apparatus for the reverse bend test, which can be used for both modes.

Annex B gives test results on the dependence of the number of bends on the tensile force applied to the specimen. The results were obtained using the apparatus described in Annex A in different conditions for Mode A and for Mode B.

¹ Numbers in square brackets refer to the Bibliography.

ELECTRICAL STEEL – REVERSE BEND TEST METHOD FOR ELECTRICAL STEEL STRIP AND SHEET

1 Scope

This Technical Report describes the general principle and technical details of the reverse bend test method used for evaluating the ductility of electrical steel strip and sheet.

This test method is applicable to Epstein test strip specimens obtained from non-oriented and grain-oriented electrical steel of any grade. The test specimens shall not be annealed.

2 Normative references

The following documents are referred to in the text in such a way that some or all of their content constitutes requirements of this document. For dated references, only the edition cited applies. For undated references, the latest edition of the referenced document (including any amendments) applies.

IEC 60404-2, *Magnetic materials – Part 2: Methods of measurement of the magnetic properties of electrical steel strip and sheet by means of an Epstein frame*

ISO 7799, *Metallic materials – Sheet and strip 3 mm thick or less – Reverse bend test*

3 Terms and definitions

For the purposes of this document, the following terms and definitions apply.

ISO and IEC maintain terminological databases for use in standardization at the following addresses:

- IEC Electropedia: available at <http://www.electropedia.org/>
- ISO Online browsing platform: available at <http://www.iso.org/obp>

3.1

reverse bend test

repeated bending of a rectangular test specimen clamped on one end through 90° in opposite directions over a pair of mandrels having a cylindrical cambered surface of 5 mm in radius, until failure

3.2

number of bends

counts of alternate bending in the reverse bend test prior to the appearance of the first crack in the base metal of specimen visible to the naked eye or sudden failure occurs by fracture

3.3

ductility

mechanical property of the materials that refers to the number of bends in the reverse bend test

4 Symbols and designations

The symbols and designations given in IEC 60404-2 and ISO 7799 apply.

5 Principles

Apply the reverse bend test to an Epstein test strip specimen and take the number of bends as an evaluation of the ductility of electrical steel strip and sheet.

6 Apparatus

There are two types of apparatus according to two modes of the reverse bend test: Mode A is according to ISO 7799, and Mode B is according to ASTM A720 [4] or JIS C2550:2000 [5], as shown in Figure 1 (numbers in mm).

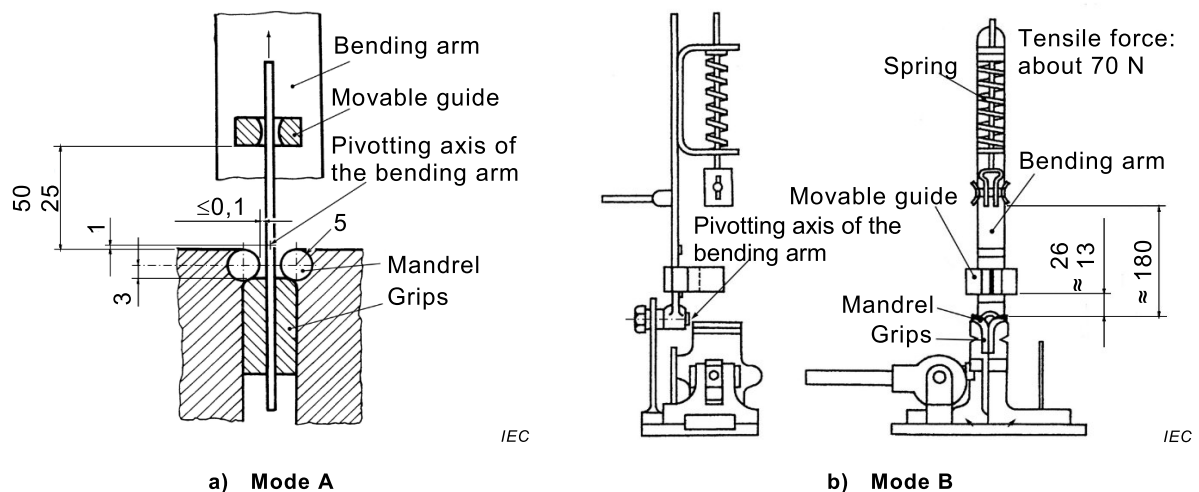
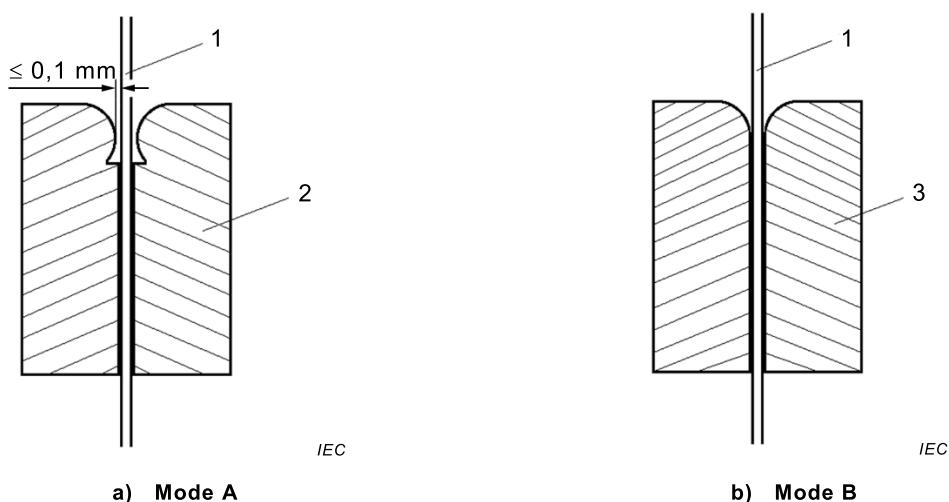

Figure 1 – Apparatus for the reverse bend test of Mode A and Mode B

The radius r of the cylindrical cambered surface of mandrels for Mode A and Mode B should be $5,0 \text{ mm} \pm 0,1 \text{ mm}$ as specified in the different electrical steel standards regardless of the strip thickness. These mandrel surfaces should be wider than the width of the test strip specimen. The examples of mandrels for Mode A and Mode B are shown in Figure 2.



Key

- | | | | |
|---|--------------------|---|--------------------|
| 1 | specimen | 2 | mandrel for Mode A |
| 3 | mandrel for Mode B | | |

Figure 2 – Schematic view of the mandrels for Mode A and Mode B

NOTE Annex A gives an example of the apparatus specially designed which can be used both for Mode A and Mode B by changing different mandrels.

7 Test specimen

The Epstein strip conforming to IEC 60404-2 should be used, and should have the following dimensions:

- width $b = 30 \text{ mm} \pm 0,2 \text{ mm}$;
- length $280 \text{ mm} \leq l \leq 320 \text{ mm}$.

NOTE 1 ISO 7799 specifies the width of the test specimen between 20 mm and 25 mm.

NOTE 2 ASTM A720 [4] specifies: “the test specimens shall be about 1.2 in. [30 mm] in width and not less than 6 in. [150 mm] in length”, in case of the test equipment designed for this limited length, the Epstein strip may not be used.

According to the different electrical steel standards, the test specimen shall be cut with its longitudinal axis perpendicular to the rolling direction for non-oriented electrical steel, and parallel to the rolling direction for grain-oriented steel. It shall be carefully cut, without any additional deformation. The surfaces of the specimen should be free of cracks or marks, and the edges should not have excessive burrs.

NOTE 3 ASTM A720 [4] specifies: “the long axis of at least five test specimens shall be in the direction of rolling and at least five at right angles to the direction of rolling”.

8 Procedure

The tests should be carried out at an ambient temperature of $(23 \pm 5)^\circ\text{C}$ on the specimen.

Fix the specimen in an apparatus of the reverse bend test for Mode A or Mode B, as shown in Figure 1.

To ensure continuous contact between the test specimen and round surfaces of the mandrels and to localize the bend during the test, a tensile stress may be applied on the test specimen. A tensile force, e.g. 70 N, is recommended.

NOTE 1 ISO 7799, Mode A, recommends a tensile stress not greater than 2 % of the value of the nominal tensile stress to ensure continuous contact between the test specimen and the cylindrical mandrels during the test, unless otherwise specified in the relevant standard. ASTM A720 [4], Mode B, specifies to provide sufficient tension in the specimen to localize the bend. JIS C2550:2000 [5], Mode B, specifies a tensile force of 70 N.

NOTE 2 A tensile force applied to specimen has an evident influence on the number of bends, especially in the case of non-oriented electrical steel, which is related to the deformation mechanism during the reverse bend test, Annex B gives some examples of results obtained from different conditions.

Bend the specimen through 90° by its longitudinal direction, alternately in opposite directions. Do not interrupt the testing between successive bends. The rate of reverse bending should be at a uniform rate without shock and not exceeding one bend per second.

Count the number of bends. A bend of 90° from the initial position and subsequent return to the initial position counts as one bend (items 1 and 2 in Figure 3), and the following bend in the opposite direction and return to initial position counts as the next bend (items 3 and 4 in Figure 3).

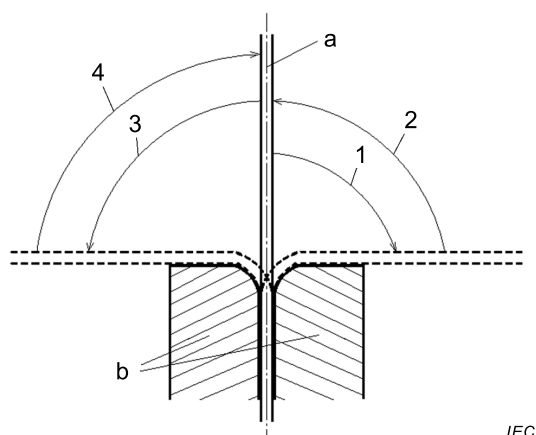

IEC

Key

a	Specimen	2	back to original position and count as one bend
b	a pair of mandrels	3	bending in opposite direction
1	start bending	4	back to original position and count as another bend

Figure 3 – Method of counting reverse bends

NOTE 3 ASTM A720 [4] uses a different method for counting the bends.

The test shall be stopped on the appearance of the first crack in the base metal visible to the naked eye. Alternatively, the test may be stopped for any of the following reasons:

- When the number of bends specified in the relevant standard or contractual agreement is reached without the occurrence of cracks;
- Upon the sudden failure of the specimen caused by fracture;
- Upon hearing an audible sound that may indicate the creation of a crack in the specimen; The indication of a crack by an audible sound shall be confirmed by visual inspection.

The last bend should not be counted in the last two cases above.

9 Expression of results

According to the different electrical steel standards, at least two specimens should be tested, and the minimum number of bends should be taken as the result. Alternatively, the specimen should be considered to be acceptable if the number of bends without cracking or failure complies with the requirement of the relevant material standard or contractual agreement.

NOTE ASTM A720 [4] specifies: “the ductility of the test lot or lift as the average of the number of bends withstood by the test specimens from that test lot or lift”.

Annex A (informative)

An example of the apparatus used for the reverse bend test

Annex A describes an example of the apparatus specially designed, which can be used both for Mode A and Mode B by changing the different mandrels, and can apply a constant tensile force to the specimen throughout the test by a weight (see Figure A.1).

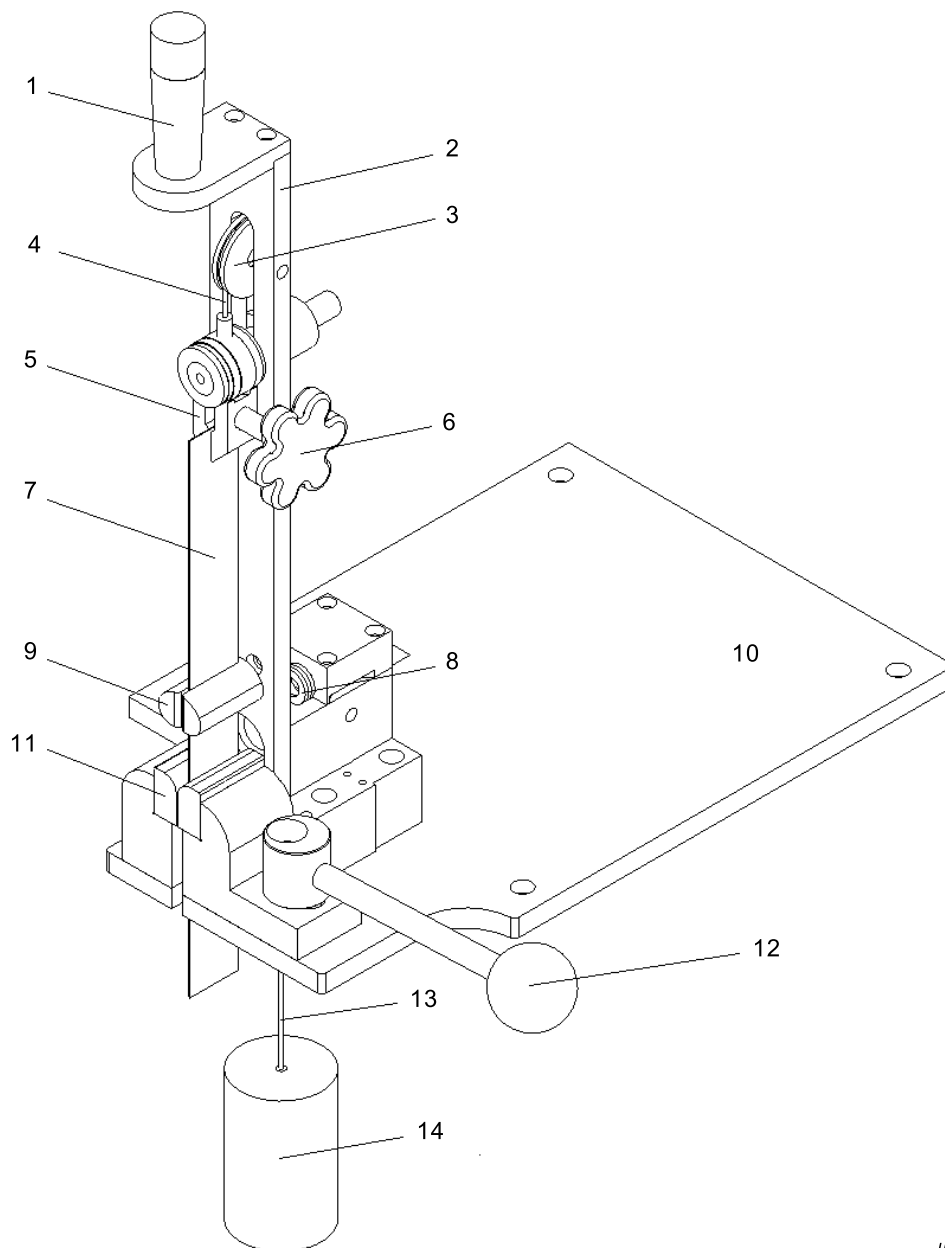

IEC

Key

1	handle	5	jaw	9	guide	14	weight
2	bend arm	6	fixer	10	base		
3	converse roll	7	specimen	11	mandrel		
4, 13	steel wire	8	guide roll	12	turning fixer		

Figure A.1 – Schematic view of a specially designed apparatus for the reverse bend test

With the reverse bend test apparatus shown in Figure A.1, an Epstein strip is clamped by a pair of jaws on the upper end. The jaws are connected to a steel wire that runs over a converse roll and passes through a pair of guide rolls. The jaws are pulled with a weight to apply a tensile force to the specimen. The lower end of the Epstein strip is held by a pair of mandrels for Mode A or Mode B, as shown in Figure 2. The reverse bend test can be performed by repeatedly turning the bend arm through 90° and then in the reverse direction.

Annex B (informative)

Dependence of the number of bends on tensile force applied to the test specimen

B.1 General

Annex B describes the examples of results obtained with a reverse bend test apparatus described in Annex A and following the instructions of this document for Mode A and Mode B.

B.2 Test results

Some grades of non-oriented and grain-oriented steel in different thickness had been tested under certain tensile forces. Figure B.1 and Figure B.2 show the results of non-oriented and grain-oriented materials and furthermore with Mode A and Mode B respectively. Each point corresponds to an average of 3 to 5 tests, and the numbers in brackets near the points in Figure B.1 and Figure B.2 are the maximum and the minimum of the tests.

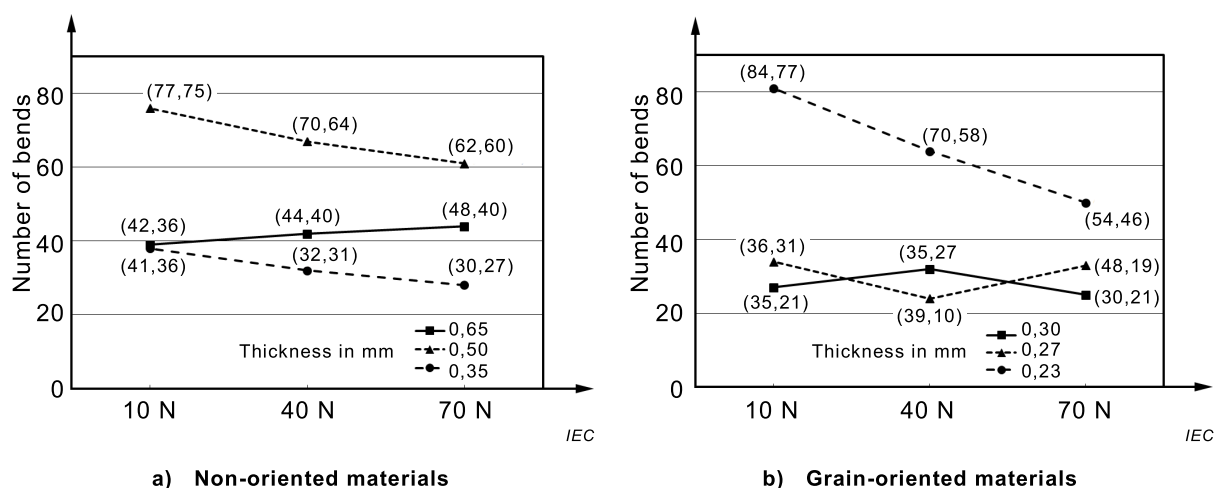

Figure B.1 – Number of bends for different tensile forces with Mode A

For Mode A as shown in Figure B.1, with non-oriented materials in different thicknesses such as 0,65 mm, 0,50 mm and 0,35 mm, the reverse bend tests of 0,50 mm and 0,35 mm specimens show that the number of bends decrease monotonically as the tensile force increases, but 0,65 mm specimens change smoothly and inversely. With grain-oriented materials in different thickness as 0,30 mm, 0,27 mm and 0,23 mm, as the tensile force increase, 0,23 mm specimens (in annealed state) show that the number of bends decreases monotonically, 0,27 mm and 0,30 mm specimens show that non-evident tendency.

For Mode B as shown in Figure B.2, with non-oriented materials in different thicknesses such as 0,65 mm, 0,50 mm and 0,35 mm, the reverse bend tests show that the number of bends decrease monotonically as the tensile force increase. With grain-oriented materials in different thicknesses such as 0,30 mm, 0,27 mm and 0,23 mm (in annealed state), as the tensile force increase, two types of specimens show that the number of bends decreases monotonically, and 0,27 mm specimens show that non-evident tendency.

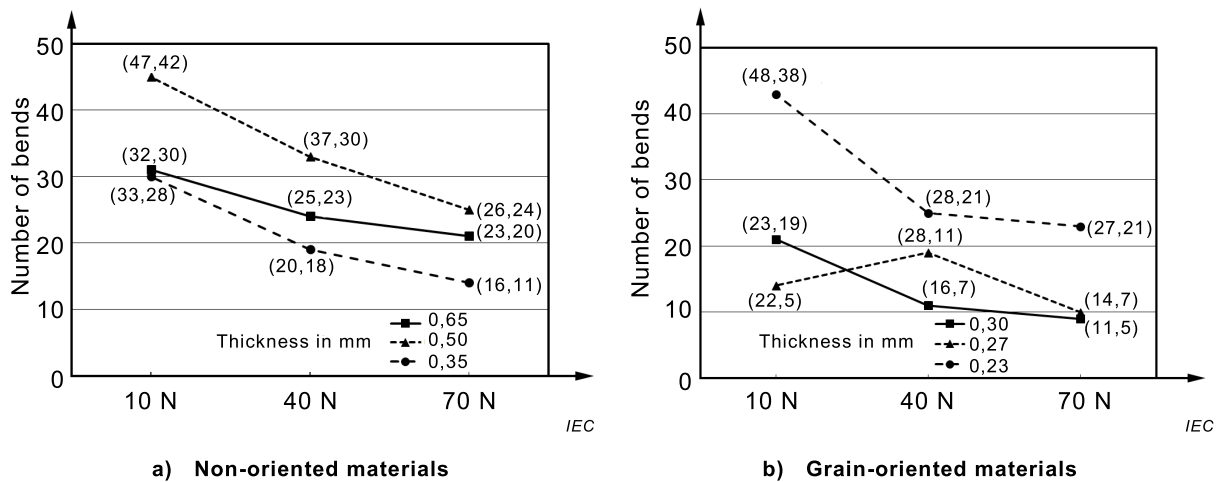
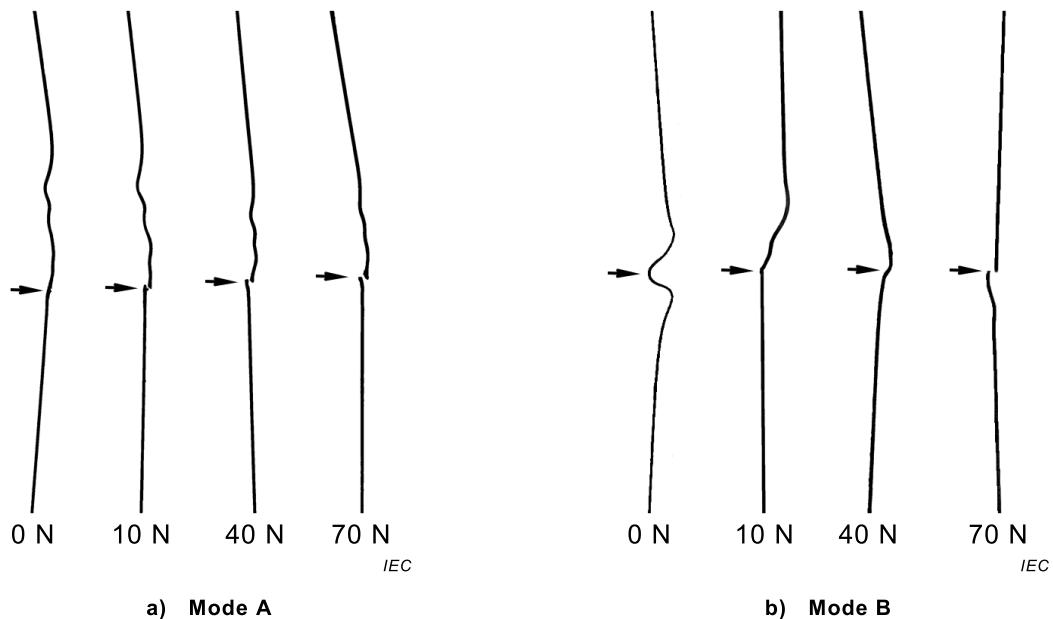

Figure B.2 – Number of bends for different tensile forces with Mode B

The number of bends obtained with Mode A is larger than that with Mode B.

B.3 Deformation situation of the specimen after failure

For Mode A and Mode B as shown in Figure B.3, with non-oriented materials in thickness of 0,50 mm, after the failure of the reverse bend tests for different tensions, the side views of the specimens show the deformation location of bends.



Key Arrows indicate the positions of crack and fracture.

Figure B.3 – Side views of the specimens after failure with Mode A and Mode B for different tensile forces

When no tensile force was applied to the specimen, an extraordinary case appeared in that the bending was not localized and the deformations were distributed in a large area. With 10 N of tensile force applied on the specimen, the area of deformation became smaller than the 0 N case. With 40 N of tensile force applied on the specimen, the area of deformation became more narrow. With 70 N of tensile force applied on the specimen, the area of deformation was localized strictly on a narrow range. The area of deformation that appeared in Mode A is larger than that in Mode B.

B.4 Conclusions

Based on the results and observations above, it can be concluded that:

- for non-oriented materials, the results both Mode A and Mode B indicate that with the increase of tensile force the number of reverse bends decreases, except for thickness of 0,65 mm. However, the results are somewhat contradictory and a much larger number of specimens of various grades and thicknesses would be needed to confirm this trend;
- the number of reverse bends is strictly related to the size of deformation area, the larger the area, the bigger the number of reverse bends is;
- the number of bends obtained with Mode A is larger than that with Mode B and is almost twice as many;
- to determine the number of bends, there is a need to specify the tensile strength applied to the test specimen in the test report.

Bibliography

- [1] IEC 60404-8-4, *Magnetic materials – Part 8-4: Specifications for individual materials – Cold-rolled non-oriented electrical steel strip and sheet delivered in the fully-processed state*
- [2] IEC 60404-8-7, *Magnetic materials – Part 8-7: Specifications for individual materials – Cold-rolled grain-oriented electrical steel strip and sheet delivered in the fully-processed state*
- [3] IEC 60404-8-8, *Magnetic materials – Part 8-8: Specifications for individual materials – Specification for thin magnetic steel strip for use at medium frequencies*
- [4] ASTM A720/A720M-02 *Standards test method for ductility of nonoriented electrical steel*
- [5] JIS C2550:2000, *Test methods for magnetic steel sheet and strip*
- [6] GB/T 2521.1-2016, *Cold-rolled electrical steel delivered in the fully-processed state – Part 1: grain non-oriented steel strip (sheet), (in Chinese)*
- [7] IS 649:1997, *Methods of testing steel sheets for magnetic circuits of power electrical apparatus, with Amendment No.2 May 2011*
- [8] ASTM A721-02, *Standards test method for ductility of oriented electrical steel*

INTERNATIONAL
ELECTROTECHNICAL
COMMISSION

3, rue de Varembé
PO Box 131
CH-1211 Geneva 20
Switzerland

Tel: + 41 22 919 02 11
Fax: + 41 22 919 03 00
info@iec.ch
www.iec.ch